

MaxiLED
Lighting



MaxiGOBO 30

MaxiGOBO 30



Ultra-Compact, High-Impact

The **MaxiGOBO 30** distills the essence of architectural projection into an ultra-compact, energy-efficient form.

Designed for subtle yet striking branding, wayfinding, or decorative effects, this **30W** gobo projector delivers impressive clarity in even the smallest spaces.

With a high-strength IP65 aluminum housing, selectable beam angles, and support for static or rotating gobos, the **MG-30** is ideal for shop windows, display cases, museum signage, and intimate outdoor settings.

Simple to install, reliable over time, and visually powerful beyond its size.



MaxiGOBO 30

Specifications

Working Voltage : **AC110-240V**

Power : **30W**

Electrical Shock Protection : **Class I**

Control Protocol: **DMX512, Auto**

Light Source: **LED**

Color Temperature : **7500K**

Beam Angle : **10° /20° /30° /45° /60°**

Effect: **1 full-colour gobo**

Housing : **Aluminium**

Installation : **Bracket**

Weight : **4 kg**

IP Rated : **IP65**

Life: **> 40000 hrs**

Efficiency: **≥ 30lm/w**

Channels: **2**

Features



Finishes



Dimensions (mm)

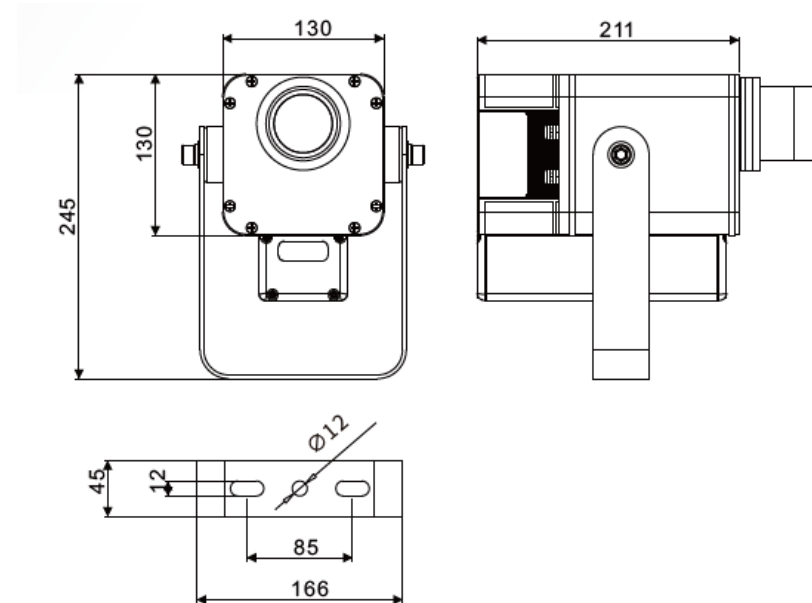

Gobos size (mm)

OD: 37,5

ID : 24

Thickness : 1.1

Certifications



MaxiLED
Lighting

MaxiGOBO 30



MaxiLED Lighting

Unit 2, Farrington Place, Rossendale Road Ind. Est. Burnley, Lancashire. UK. BB11 5TY
T: +44 (0)1282 448086 E: sales@maxiledlighting.com Web: www.maxiledlighting.com