



SUPER · Swivel-mounted version
IP65 Surface mounted downlights

OUTDOOR



OUTDOOR

IP65 Surface-mounted downlights

Super

- Surface-mounted downlights with symmetrical light distribution.
- Protection rating against dust and moisture: complete IP65.
- Protection rating for resistance to harmful mechanical impacts: IK07.
- Tilt version, adjustable to 20° and 180° rotation.
- Robust body and frame made of die-cast aluminium treated against corrosion and coated with polyester powder available in various colour finishes, customized RAL under request.
- C5-M coating special for environments with very high corrosivity is available under request.
- Total lighting control: high performance and high efficiency.
- High-purity aluminium reflector.
- 5mm tempered protection glass clear as standard, other finishes under request.
- Polycarbonate diffuser as option to get IK10 protection degree.
- Temperature resistant silicone rubber gasket.
- Anti-condensation device.
- Optional supply of 304 stainless steel vandal-resistant screws.
- Integral driver included. Electrical standard options for the driver: DALI/ DSI.
- Passive temperature management: heat dissipation via the fixture body itself.

Suggested applications: porches, shopping centres, leisure areas, car parks, service stations, industrial facilities, outdoor ceilings in high humidity areas, or interior spaces that require low-maintenance. Solid ceilings or where there is not space for recessed mounting. Areas where a point of interest is to be highlighted.

SUPER: rovasi.com/en/products/SUPER

TECHNICAL DETAILS

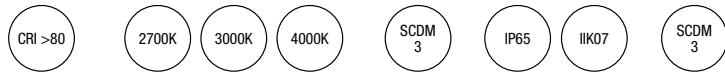

Ø 180mm



11W min 1960lm <> max 2125lm

17W min 2755lm <> max 2990lm



Ø 235mm



11W min 1960lm <> max 2125lm

17W min 2755lm <> max 2990lm

23W min 3900lm <> max 4235lm

ELECTRONIC OPTIONS

On/Off.

DALI/DSI/SwitchDIM/corridorFUNCTION.

Emergency Kit.

ACCESSORIES AND FINISHES



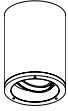

Super

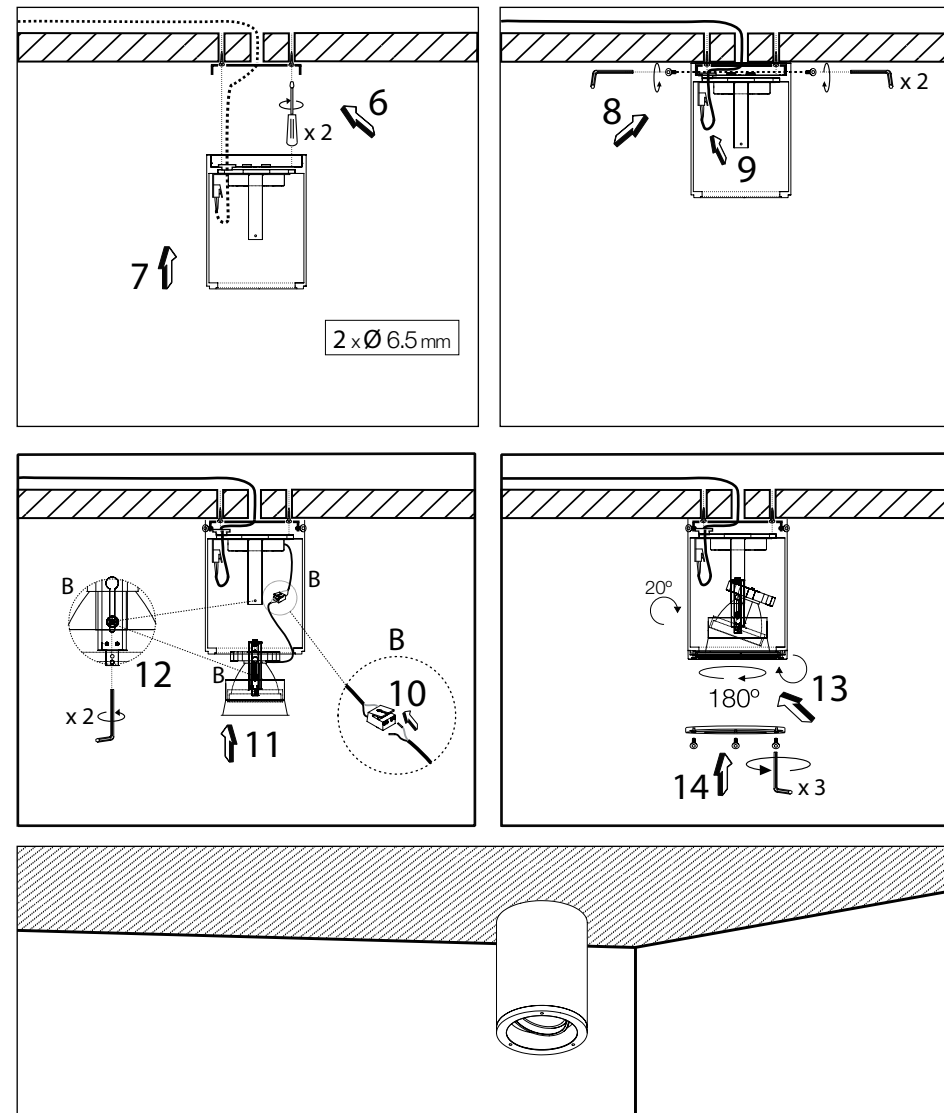
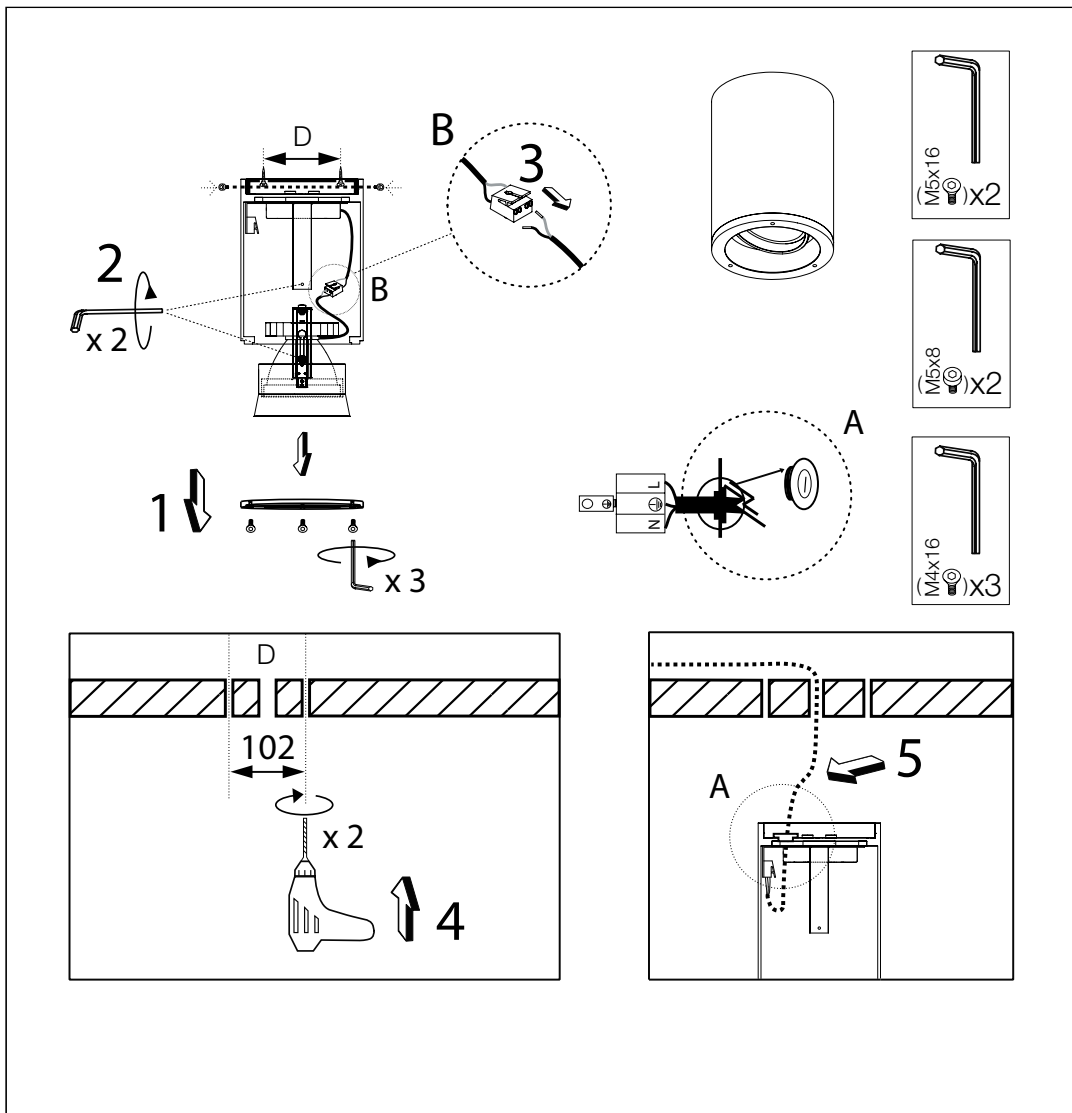

Finishes

Colour chart

								
RAL1015 Ref.19 Light Ivory	RAL1021 Ref.18 Colza Yellow	RAL1026 Ref.17 Luminous Yellow	RAL1036 Ref.5 Pearl Gold	RAL2000 Ref.20 Yellow Orange	RAL2002 Ref.16 Vermilion	RAL3026 Ref.15 Luminous Bright Red	RAL4003 Ref.22 Heather Violet	RAL4006 Ref.23 Traffic Purple
								
RAL5002 Ref.25 Ultramarine Blue	RAL5012 Ref.24 Light Blue	RAL 5018 Ref.26 Turquoise Blue	RAL6005 Ref.29 Moss Green	RAL6010 Ref.28 Grass Green	RAL6018 Ref.27 Yellow Green			
								
RAL7011 Ref.32 Iron Grey	RAL7016 Ref.4 Anthracite Grey	RAL7032 Ref.30 Pebble Grey	RAL8017 Ref.31 Chocolate Brown	RAL8022 Ref.33 Black Brown	RAL9003 Ref.34 Signal White			
								
RAL9005 Ref.2 Jet Black	RAL9006 Ref.7 White Aluminium	RAL9010 Ref.1 Pure White	RAL9016 Ref.35 Traffic White	RAL9016 Ref.35 Satin Bronze				



STAINLESS STEEL 316L Marine Grade
Available for: Watertight, Watertight Shallow, Watertight SQ, Dot, Lotus, Terra, Terra SQ, Victoria and Lithos.



C5-M (Marine) COATING
Special coating for environments with very high corrosivity. Areas near to the coast and spaces with high salinity.



Other RAL colors or product finishes are available upon request.

Bespoke solutions

If we don't
already have it,
we create it

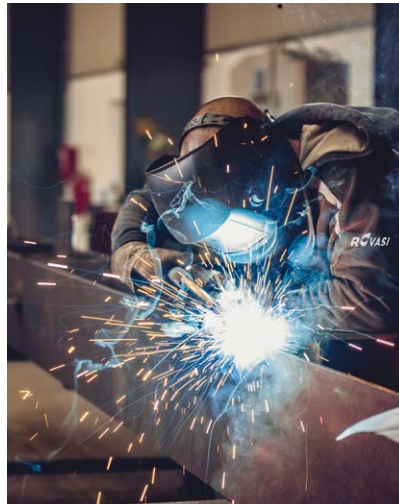

The engineer from our technical team and the adaptability of our installations enable us to study, design and manufacture custom lighting systems based on the requirements and needs of each project.

Our **installations** are fully equipped with the necessary resources and the best **specialised professionals** to take on any custom order. Every project is painstakingly studied by our **technical team**, involving all stages of the creative and productive process: conceptualisation and **design of our products**; 3D modelling; prototype manufacture; and successful final production of the new product.

We develop **custom products** based on the requirements and needs of each project, and do so in partnership with everyone involved in the lighting project (lighting designers, architects and engineers). We always **adapt** to the needs of the project, manufacturing a new product from the ground up based on a simple functional description or working from sketches provided by a customer or external designer.

Furthermore, we can make minor modifications to products that already exist or create entirely new ones based on your design criteria.

5 years guarantee

Total quality,
integral guarantee.

Quality lighting can only be created from quality luminaires. That's why ROVASI has always maintained a commitment to only offering premium products for our lighting solutions.

We only work with the best components. This enables us to offer a total guarantee that all the luminaires we design and manufacture meet the very highest quality standards and strictly comply with current regulations.

The quality of our products is translated into security and peace of mind once the project has been completed.

Because we want to share and transmit the benefits of this quality commitment with all our customers, all our range has a guarantee for 5 years.



Contact us for more information:

ROVASI S.L

Ronda de la Font Grossa, 15

Pol. Ind. La Gavarra

08540 Centelles | Barcelona

T +34 93 881 35 12

+34 93 881 37 13

info@rovasi.com

